

AL-KO SANDING TABLE AST 1.5 BASIC



ENTRY-LEVEL MODEL WITH MANY PRACTICE-PROVEN FEATURES

The AL-KO AST 1.5 BASIC sanding table is the entry-level model in the AL-KO sanding table range and compared to our PREMIUM sanding tables has been pared back to the essential product characteristics. It therefore offers a low-cost alternative without having to forego any of the quality for which AL-KO is renowned. The AST 1.5 BASIC sanding table is made from galvanised sheet steel and equipped with a manual, tool-free height adjustment mechanism. The workpiece support is a wooden rack.

The advantages for you:

- | Manual, tool-free height adjustment mechanism with scale
- | Offset longitudinal sides for edge sanding
- | Beechwood rack to prevent damaging the workpiece
- | Funnel-shaped air guide for the extraction nozzle



TECHNICAL DATA

Design	Dimensions L x W [mm]	Work surface L x W [mm]	Working height [mm]	Extractor connection [mm]	Recommended extraction performance [m³]	Weight [kg]
AST 1.5 BASIC	1585 x 1000	1500 x 946	735 - 1015	160	1500	73



AL-KO EXTRACTION TECHNOLOGY – YOUR POWERFUL PARTNER

In Europe and across the world, thousands of customers choose quality products from AL-KO Extraction Technology every year. Their popularity and the faith in us prove that even today, products bearing the “Made in Germany” label have a future - if they are consistently based on innovation and superior quality.

Look to the future with us and, as our customer and partner, profit from the performance, the quality and the security offered by the AL-KO brand.

AL-KO THERM GMBH
Extraction technology division
 Hauptstrasse 248 – 250
 89343 Jettingen-Scheppach
 Germany
 Tel. +49 8225 39-2412
 Fax +49 8225 39-2435
 absaug.technik@al-ko.de
www.al-ko.com

Provided by your AL-KO partner:

Subject to modifications in response to technical developments.
 No liability accepted for mistakes and printing errors. 04.2017

AL-KO SANDING TABLES



AL-KO SANDING TABLES

FOR A CLEAN WORKPLACE DURING MANUAL WORK

Sanding tables, when combined with dust extractors or a decentralised filter system, ensure additional removal of dust during manual sanding work with manual sanders, as well as when working with hand-guided sanding equipment, that goes beyond the device's own dust removal function. The sanding table significantly reduces the amount of dust produced, the air in the room is noticeably improved and the health of the employee is not put at risk by dusty exhaust air.

In the domain of manual / sanding stations, AL-KO offers the ideal solution for every requirement: with its "BASIC" series, AL-KO provides a low-cost entry-level model that impresses primarily with its practice-proven features and value for money. The "PREMIUM" series is aimed at customers with more exacting demands, since the high-quality, carefully thought-out details leave no wish un-granted.

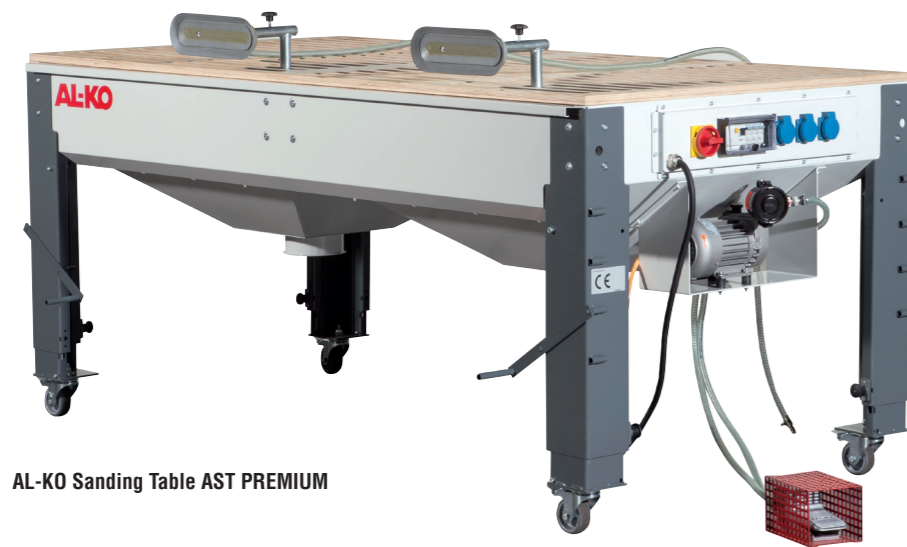

AL-KO Sanding Table AST PREMIUM



AL-KO Sanding Table AST BASIC

AL-KO SANDING TABLE AST 1.0 - 3.0 PREMIUM

INGENIOUS IN THE DETAILS THE AL-KO AST PREMIUM

The AL-KO AST PREMIUM sanding table is made of welded steel plate, and all metallic components are powder-coated. The workpiece support is a wooden rack. The table is accessible from four sides and designed so that several people can work at it at the same time. On one side, there is a workpiece shelf; the electrical connector strip and the vacuum extraction system are arranged on the end.

The AST PREMIUM is equipped with height adjustment as standard for ergonomic reasons. Hydraulic height adjustment, a vacuum clamping system, support fixture, pivoting castors as well as an electrical connector strip for operating hand-held sanders are available as an option.

The advantages for you:

- | Base frame made of welded steel plate – surfaces covered with hard-wearing powder coating in standard RAL colours
- | Extraction funnel made of steel plate with connection nozzle Ø 140 mm for a central extraction system or mobile extraction devices
- | Beechwood rack to prevent damaging the workpiece
- | Mechanical height adjustment of the feet by row of holes and push-in pins. The adjustment range is 400 mm. Work height 757 mm – 1157 mm



OPTIONAL ACCESSORIES:

Electrical connector strip

- | Power cable H07-RN-F 3G 2.5², 5 m long, with mains switch
- | Electrical master switch, lockable
- | Protective earth contact sockets, 16 amps, 230 volts, for electrical tools
- | 2-pole circuit breaker on the supply side
- | On/off switch for controlling the extractor fan and a pneumatic or electrical shutter valve

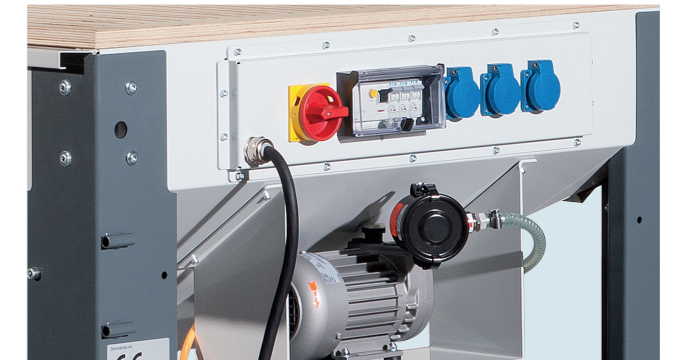

Hydraulic height adjustment with hand crank

- | Adjustable work height from 757 mm - 1157 mm



Vacuum clamping system

- | Powerful vacuum pump, suitable for continuous operation
- | 2x clamps, suction bar with separate shut-off valve for horizontal and vertical clamping
- | Vacuum clamp 360° pivoting, module dimension 45°
- | Workpiece release by foot valve

Support fixture for vertical clamping

- | Load holding with vertical clamping by folding out support fixture

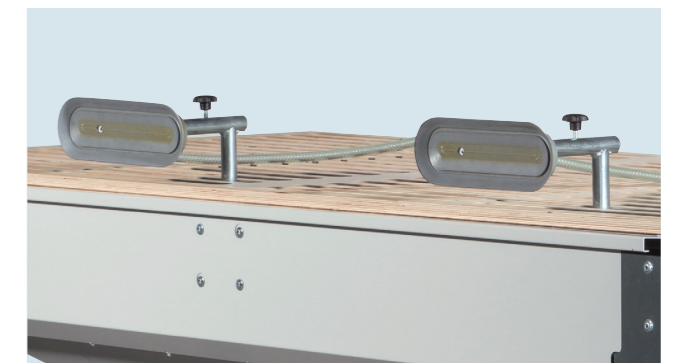

Mobility set

- | Simple movement of the sanding table on 4 pivoting castors
- | Sturdy pivoting castors with rubber tyres and Stopp-Fix brake
- | Adjustable work height from 859 mm – 1259 mm

TECHNICAL DATA

Design	Length [mm]	Width [mm]	Working height [mm]	Recommended extraction performance [m³]	Weight [kg]
AST 1.0 PREMIUM	1000	1000	757 - 1157	1400	87
AST 2.0 PREMIUM	2000	1000	757 - 1157	1800	147
AST 3.0 PREMIUM	3000	1000	757 - 1157	2200	220